

AUTOLIFT<sup>TM</sup>



VEHICLE RAMPS

## WELCOME TO AUTOLIFT

Autolift S.r.l. is a young, dynamic company. With twenty years of experience in the lifting sector, the company has specialized in the production of equipment for wheelchair accessibility. Thanks to highly specialized staff, cutting-edge technologies and full range of products, Autolift S.r.l. can meet the market demand for motor vehicle outfitting to serve both private and public use clients.

The company's mission focuses on:

- Ongoing research to find the best solutions to eliminate the barriers to access and transport for people with disabilities.
- Development and engineering of special devices to cover the full range of requirements from our global clientele.
- Produce aids that comply with current regulations concerning the disabled, first aid and public transport.
- Offer prompt, efficient support that enables installers to provide their customers with impeccable service both during installation and after-sales (warranty, spare parts, support).
- An offering that can even meet the needs of people with disabilities to board trains, ships and aircraft as per European regulations.
- Compliance of all our products with CE markings and regulations on electromagnetic compatibility. Each product, whether a lift or access step, comes not only with the relative manuals, but also with certificates of origin and conformity.

*“Vehicle ramps? Light, strong and safe...”*

Our cost effective all aluminium ramps can be fitted easily to a vehicle floor and with a choice of available sizes we will have what you need to provide safe and easy movement of cargo in your commercial vehicle. Thanks to the Quick Lock system, rapid removal of the ramp is simple. These are not only strong, but also very safe due to the anti-slip properties of the formed aluminium platform.

In this catalogue you will find:

**Two parts vehicle ramps**

---

Page 04 - 05 Ramps Series R-ST

Page 06 - 07 Ramps Series R-EVO

Page 08 - 09 Ramps Series R-HD

# TWO PARTS VEHICLE RAMPS



**Quick-lock system**



**Closing system**



**Anti-slip edges**



**Safety belts**



## TWO PARTS VEHICLE RAMPS

made in  
**Italy**

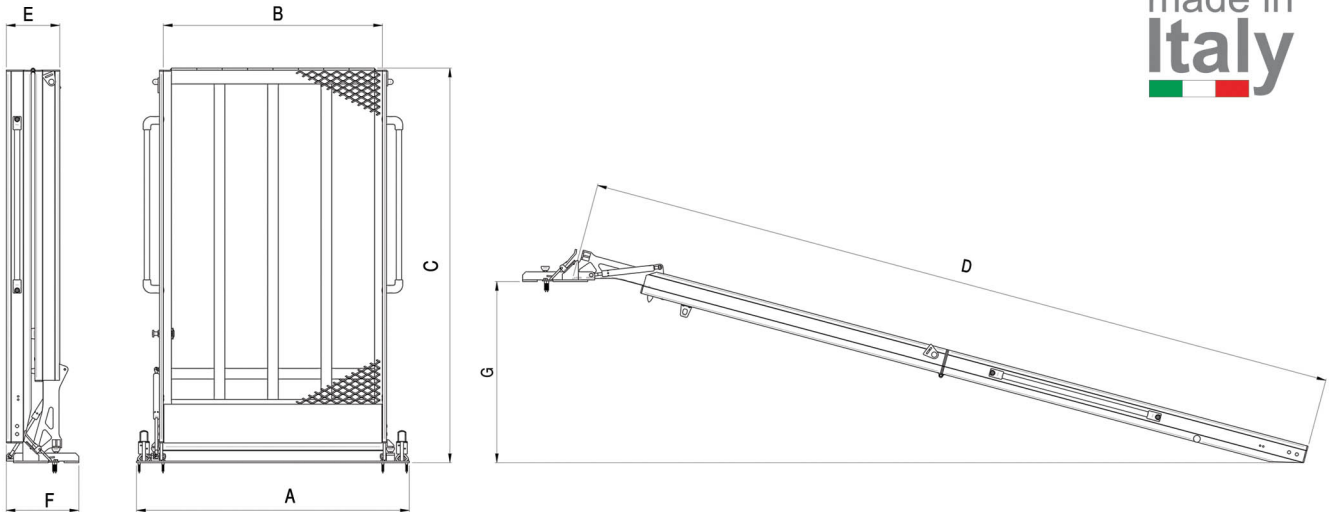
### Technical Features

Art. Nr	A (mm)	B (mm)	C (mm)	D (mm)	E (mm)	F (mm)	G (mm)	Ramp weight	Max load capacity
R-201-ST	1020	820	1102	2010	200	271	355-485	26 Kg	400 Kg
R-211-ST	1020	820	1152	2110	200	271	375-510	28 Kg	400 Kg
R-226-ST	1020	820	1227	2260	200	271	400-550	30 Kg	400 Kg
R-251-ST	1020	820	1352	2510	200	271	450-610	31 Kg	400 Kg
R-276-ST	1020	820	1477	2760	200	271	490-670	33 Kg	400 Kg

### Special Executions

R-211-57	770	570	1152	2110	200	271	375-510	20 Kg	400 Kg
R-211-70	900	700	1152	2110	200	271	375-510	23 Kg	400 Kg

## TWO PARTS VEHICLE RAMPS



Safety lock system



Baseplate mount



Heavy Duty  
tight mesh

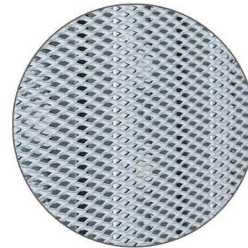

Anti-slip edges



Extra wheels



Additional gas spring



## TWO PARTS VEHICLE RAMPS

made in  
**Italy**

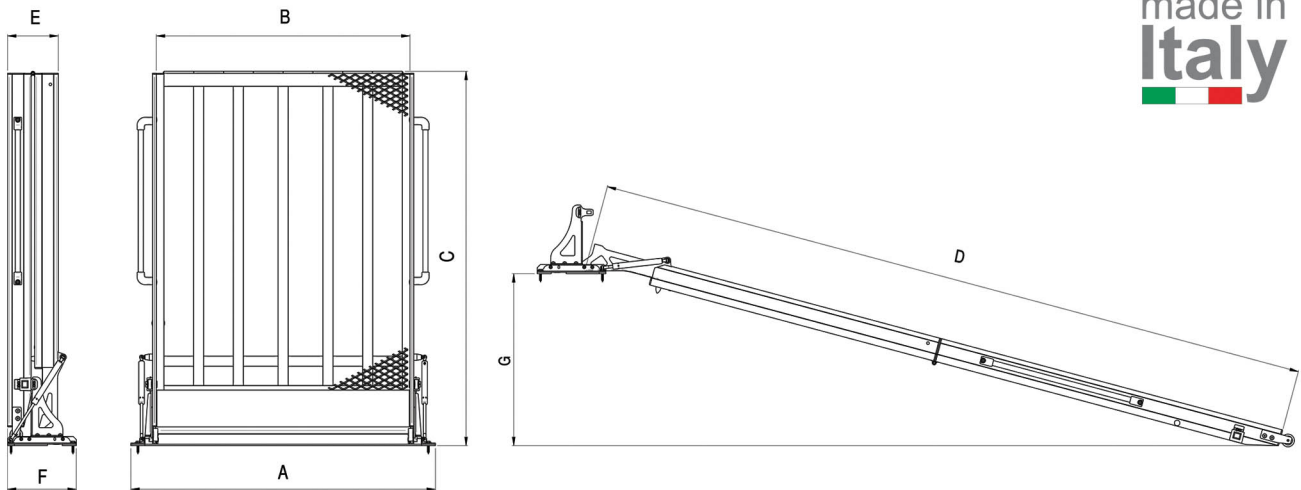
### Technical Features

Art. Nr	A (mm)	B (mm)	C (mm)	D (mm)	E (mm)	F (mm)	G (mm)	Ramp weight	Max load capacity
R-251-91-EVO	1110	910	1352	2510	200	271	450-610	37 Kg	400 Kg
R-276-91-EVO	1110	910	1477	2760	200	271	490-670	39 Kg	400 Kg
R-251-10-EVO	1200	1000	1352	2510	200	271	450-610	42 Kg	400 Kg
R-276-10-EVO	1200	1000	1477	2760	200	271	490-670	44 Kg	400 Kg

### Special Executions

R-226-82-EVO	1020	820	1227	2260	200	271	400-550	33 Kg	400 Kg
R-226-91-EVO	1110	910	1227	2260	200	271	400-550	37 Kg	400 Kg
R-226-10-EVO	1200	1000	1227	2260	200	271	400-550	42 Kg	400 Kg

# SERIES R-HD HEAVY DUTY

## TWO PARTS VEHICLE RAMPS



Quick-lock system



Grease gun



Heavy Duty tight mesh

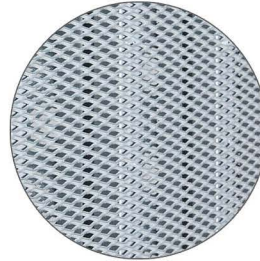

Highly reflective side profiles



Anti-slip edge + extra wheels



Gas spring between the two platforms



Safety belts



Additional gas spring on the baseplate





## TWO PARTS VEHICLE RAMPS

made in  
**Italy**

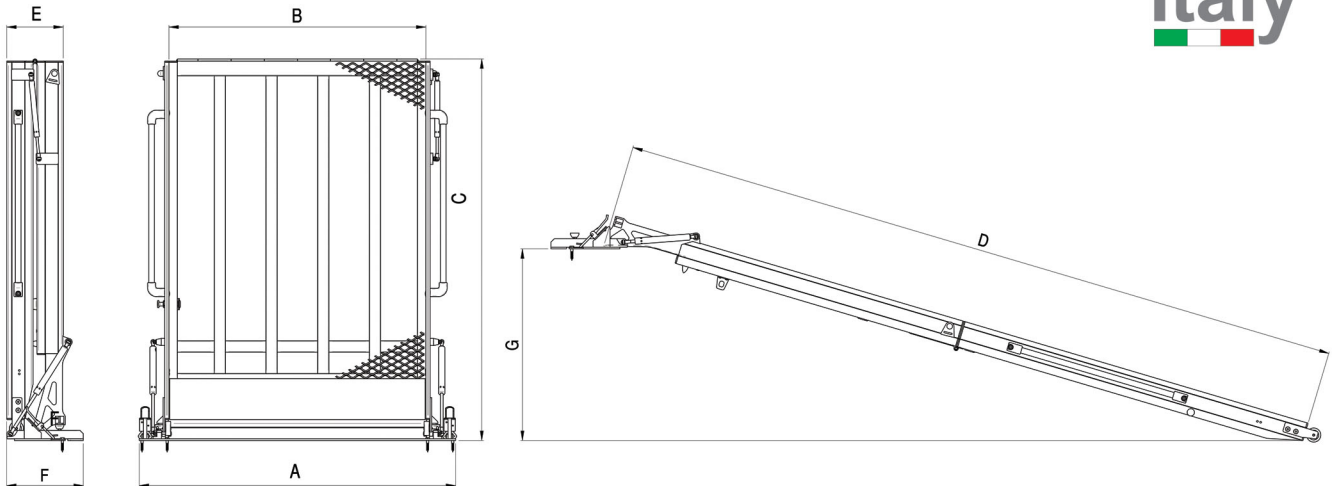
### Technical Features

Art. Nr	A (mm)	B (mm)	C (mm)	D (mm)	E (mm)	F (mm)	G (mm)	Ramp weight	Max load capacity
R-201-HD	1110	910	1227	2010	200	271	400-550	34 Kg	600 Kg
R-251-HD	1110	910	1352	2510	200	271	450-610	38 Kg	600 Kg

# WHERE WE ARE

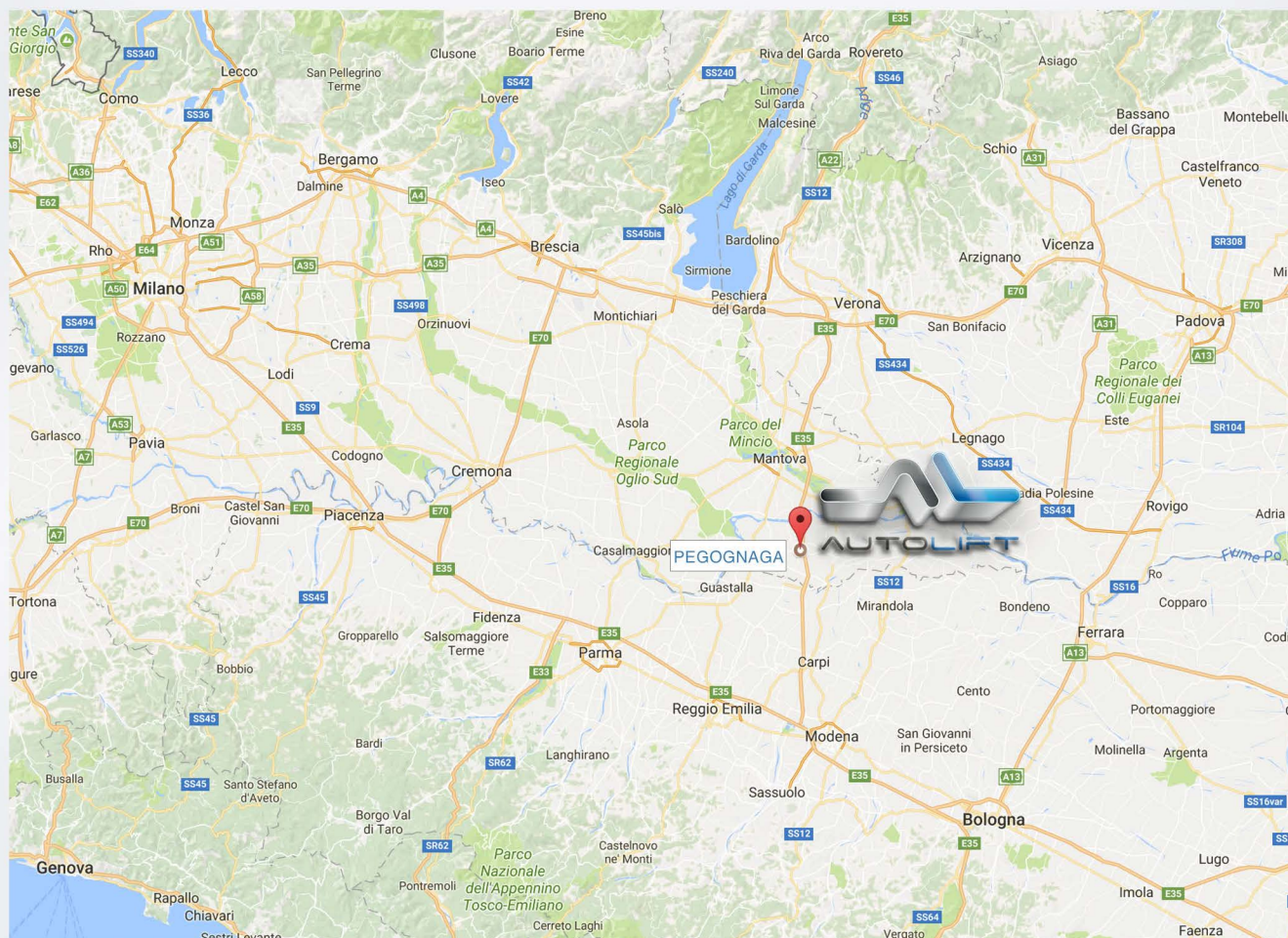

Autolift S.r.l. is the leading Italian manufacturer of lifts, steps and assistance equipment for the transportation of disabled persons. All products are **MADE IN ITALY** and are marketed nationwide and throughout Europe. Our factory is located in Mantua, near the Pegognaga highway exit.

AUTOLIFT S.r.l.

Via B. Trentin, 8 - 46020 Pegognaga (MN)

Tel. +39 0376 550375 - Fax +39 0376 553728 - E-mail [info@autoliftsrl.com](mailto:info@autoliftsrl.com)

[www.autoliftsrl.com](http://www.autoliftsrl.com)