

## LIFTS WITH VERTICALLY FOLDING PLATFORM

Easy access and good visibility



### SAFETY DEVICES

- Front safety roll stop on the automatic loading platform
- Rear safety roll stop on the automatic loading platform
- Anti-tilting control valve
- Automatic extendable/retractable handrails

### EMERGENCY

- Emergency operation lift via auxiliary hydraulic pump
- Emergency descent by unlocking descent valve

The automatic, twin-arm, electro-hydraulic lifts in the **BBW** Series have a vertically folding platform. Thanks to a two-button control unit and the use of top quality materials, these devices are not only user friendly, they are also extremely reliable. Available in a wide range of sizes, they can be internally rear and side mounted in a wide variety of people carriers. These devices are unusual, as they not only guarantee good visibility, but also provide an additional access point.

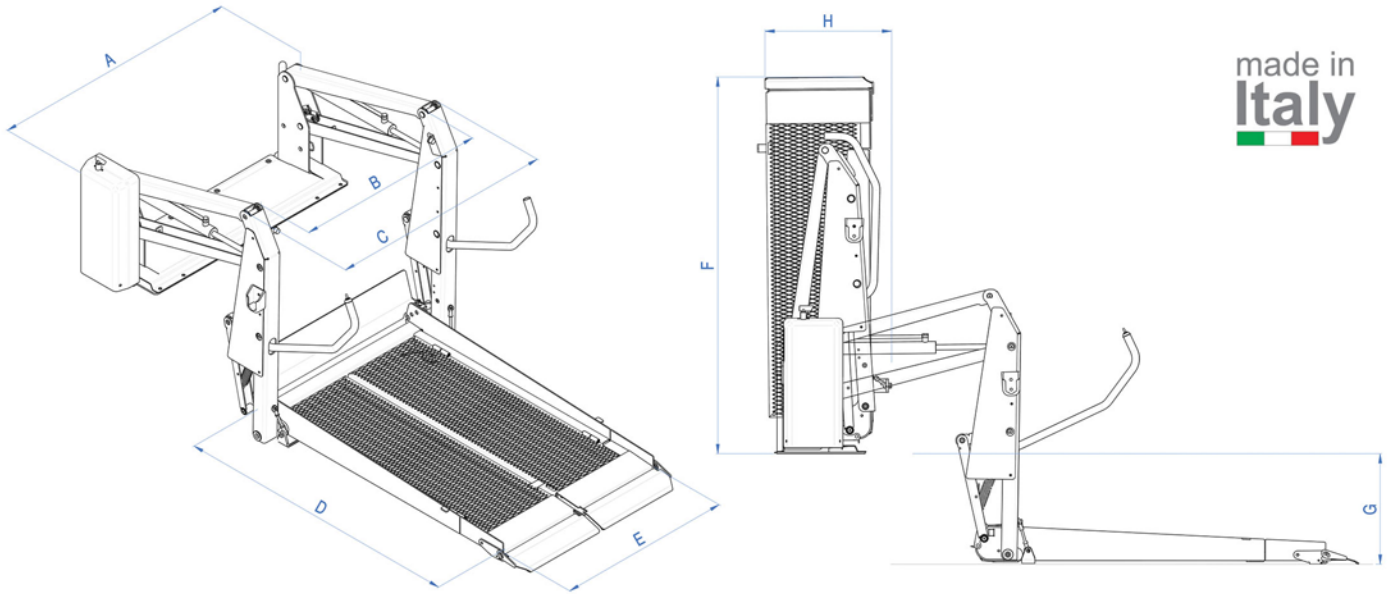

### Technical Features

	Baseplate width	Clear entry width	Traveling frame width	Overall platform length	Overall platform width	Overall lift height	Max loading height	Overall lift depth	Rated load capacity (Kg)	Lift weight (Kg)
	A	B	C	D	E	F	G	H		
BBWM 905	970	690	840	915	645	1020	690	420	320	108
BBWL 1030	1085	790	940	1030	745	1180	880	485	320	126

### Series BBW Technical Features

Movement powered by two hydraulic cylinders  
Vertically folding platform with anti-slip surface  
Anti-rust powder paint coating  
Self-lubricating bushings and pins

Two-button control unit  
12-24V Electrical System  
For use at temperatures between -30°C and +70°C  
Valid EMC accreditation (E50)  
EC standard compliant

AUTOLIFT S.r.l.

Via B. Trentin, 8 - 46020 Pegognaga (MN)

Tel. +39 0376 550375 - Fax +39 0376 553728 - E-mail info@autoliftsrl.com

[www.autoliftsrl.com](http://www.autoliftsrl.com)