

## LIFTS WITH ONE-PIECE PLATFORM

Uniquely robust and reliable



### SAFETY DEVICES

- Front roll-stop stop plate on the automatic loading platform
- Rear roll-stop stop plate on the automatic loading platform
- Anti-tilting control valve
- Automatic extendable/retractable handrails

### EMERGENCY

- Emergency operation lift via auxiliary hydraulic pump
- Emergency descent by unlocking descent valve

**ALSF**  
AUTOLIFT SPACE FRAME

The automatic, twin-arm, electro-hydraulic lifts in the **BB** Series have a one-piece platform. Thanks to a two-button control unit and the use of top quality materials, these devices are not only user friendly, they are also extremely reliable. Available in a wide range of sizes, they can be internally rear or side mounted in a wide variety of people carriers.

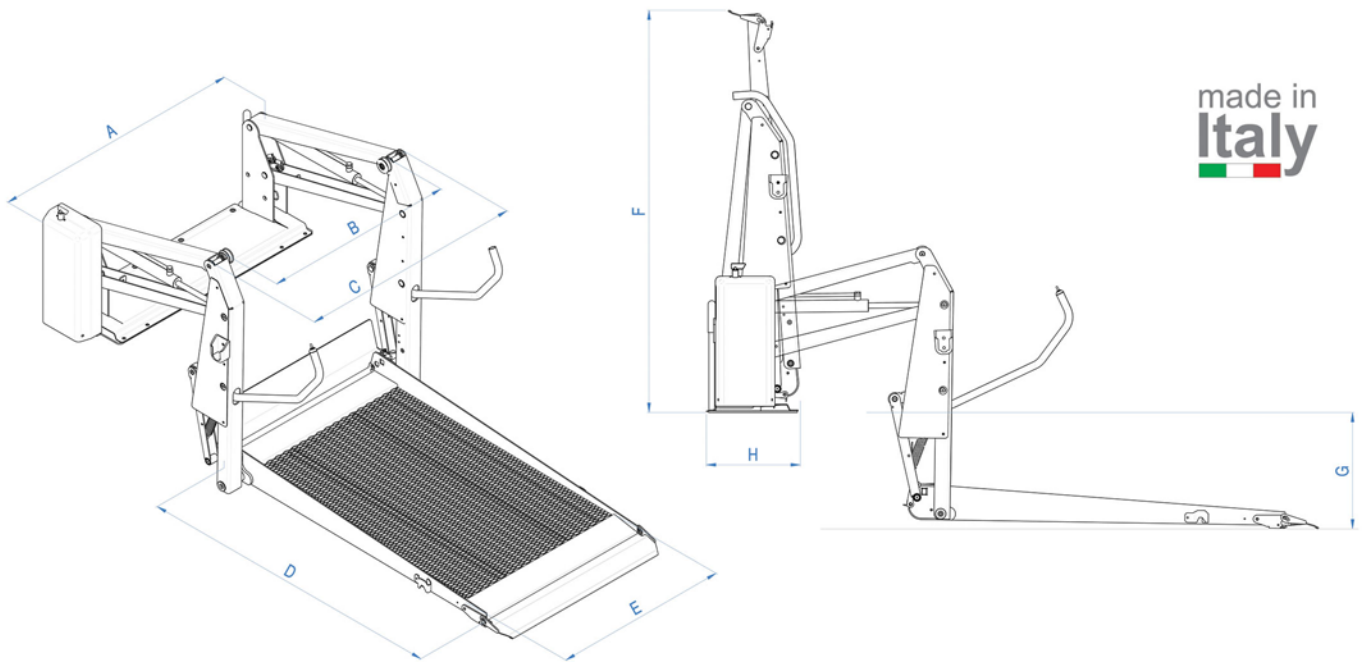

### Technical Features

	Baseplate width	Clear entry width	Traveling frame width	Overall platform length	Overall platform width	Overall lift height	Max loading height	Overall lift depth	Rated load capacity (Kg)	Lift weight (Kg)
	A	B	C	D	E	F	G	H		
BB 1050	1165	880	1030	1050	800	1110	920	350	350	148
BB 1350	1165	880	1030	1350	800	1400	920	350	350	153

### Series BB Technical Features

Movement powered by two hydraulic cylinders  
 One-piece folding platform with anti-slip surface  
 Anti-rust powder paint coating  
 Self-lubricating bushings and pins

Two-button control unit  
 12-24V Electrical System  
 For use at temperatures between -30°C and +70°C  
 Valid EMC accreditation (E90)  
 EC standard compliant

AUTOLIFT S.r.l.

Via B. Trentin, 8 - 46020 Pegognaga (MN)

Tel. +39 0376 550375 - Fax +39 0376 553728 - E-mail info@autoliftsrl.com

[www.autoliftsrl.com](http://www.autoliftsrl.com)